



SOUND LEVEL CONTROL IN LIBRARY WITH AUDIO ANNOUNCEMENT

Suhaib Abbasi, Shaina Tanweer, Soumya Sharma, Rahul Munjal, Razi Ahmed
Department of Electronics and communication,
SRM Institute of Management & Technology,
SRM University

Abstract —

This research paper is a work on noise level control with automated audio announcement. This paper aims at the prospect of our project and how we achieve in providing a conducive environment in a library. A pre amplifier circuit with help of a microphone catches the sound and gives the result to micro controller. A threshold level of sound is fixed and if the noise is more than that level, an automated and pre-recorded message is conveyed with the help of an audio announcement circuit. Thus, it helps in maintaining peaceful environment inside the library.

Keywords— Micro-controller; ADC; Audio announcement circuit; LCD, Crystal oscillatot; ower amplifier.

I. INTRODUCTION

This project is directed to design and implement all the modules in a sound level meter with an audio announcement part to maintain an optimum noise level and to provide a conducive environment in a library. The first step of the project is to build a pre-amplifier stage. Its main function is to increase the sound level. Then a microcontroller is used which has a microprogram written in it using C programming language. This enables it to be interfaced with an LCD display for showing sound level and thus then comparing input sound signals to a critical level and if a signal is above that critical level , the audio announcement circuit functions and a recorded message is thus played. To do so, we have to design a voice processor that plays a pre-recorded message to the users of the library whenever the noise level is high.

Noise in the Library

Noise measurement is carried out in various fields. In acoustics, it can be for the purpose of measuring environmental noise, or part of a test procedure using white noise, or some other specialised form of test signal. In electronics it relates to the sensitivity of communications systems, the purity of signals, or the quality of audio systems. The concept is to define the noise level below which signals cannot reliably be detected. It can be thought of as uncertainty of the information being carried over a communications channel. In audio systems and broadcasting specific methods are used to obtain subjectively valid results in order that different devices and signal paths may be compared regardless of the differing spectral distribution and temporal properties of the noise that they generate. Now we have to understand why there is a major need for this project. It's all definitely because of the noise. Noise does not only affect our concentration while studying but also have adverse effects on our health. Noise refers to any unwanted sound or unwanted random additions to a signal as seen in most electronic designs and signal noise is heard as acoustic noise if the signal is converted into sound (e.g., played through a loudspeaker). High noise levels can block, distort, change or interfere with the meaning of a message

in human, animal and electronic communication. "Signal-to-noise ratio" is sometimes used to refer to the ratio of useful to irrelevant information in an exchange. Noise affects the mind and changes emotions and behaviour in many ways. It interferes with our communication and arouses our sense of fear. It is overly arousing and presents too high a level of stimulation.

The effects of noise on people in the library are as follows:

Health Effect: Health is not merely an absence of disease and infirmity. Health is a state of complete physical, mental and social well-being. Hardly a day passes without being subjected to some intruding noise whether inside of the library or outside of it. Health is prejudiced by interference with peace of mind, privacy, work or pleasure. Continued research is being performed to relate psychological and physiological effect of noise on man.

Performance Effect: It is likely that any new sound or change in an existing sound may result in at least momentary distraction and this may impair a person's ability to perform some tasks. Reading in the libraries is most prone to disturbances since it has a little margin for error, requires interaction with more than one source or sensing channel. Typically, the impairment in the libraries in the presence of noise takes the form of signals (points) being missed, increased error in response (assimilation) and prolonged assimilation time. High noise levels can contribute to cardiovascular effects in humans, a rise in blood pressure, and an increase in stress and vasoconstriction, and an increased incidence of coronary artery disease. Sound level is not a measure of loudness, as loudness is a subjective factor and depends on the characteristics of the ear of the listener. In the early 1970s, as concern about noise pollution increased, accurate, versatile, portable noise-measuring instruments were developed. Noise control in a library is of utmost importance, since the basic aim of a library is to provide a conducive environment for its users to conduct research and study. This project looks to eliminate the presence of an administrative presence designated the role of noise control as in the past. Therefore, the essence of having an automated sound level system is to reduce the possibility that the personnel-in-charge might cause some kind of noise whilst trying to alert library users to their increasing sound level.

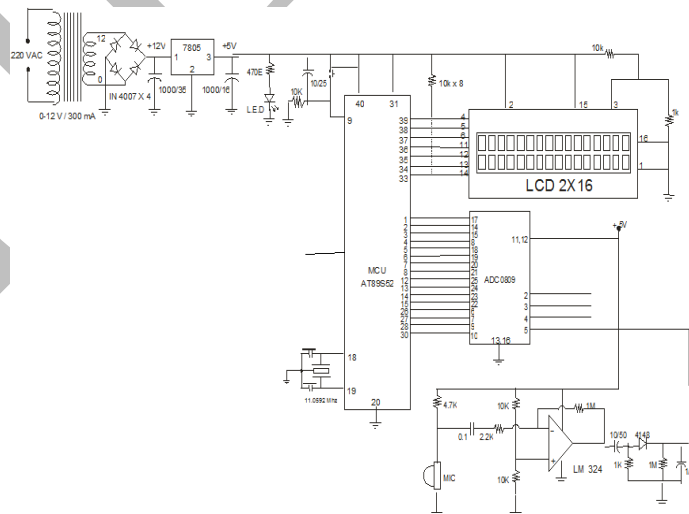

II. METHODOLOGY

A sound level meter is simply a device with audio-frequency sensing capabilities that is controlled, essentially, by a microcontroller, which measures, compares, and triggers the appropriate action (makes an audio announcement) to reduce noise level once the critical sound level has been exceeded. The sound level meter consists of a Condenser microphone (to convert the sound into electrical signal), Pre-Amplifier (amplifies the electrical signal), Microcontroller (with internal ADC feature – to capture and compare the input signal with a critical value), Play and Record Chip (to play a pre-recorded message, alerting library users of increasing sound level), Power Amplifier (amplifies the output of the play and record chip), and LCD display (displays the sound levels). The Sound Level Meter measures sound level in decibels and can be used for activities such as environmental noise studies, sound level comparisons, investigating room acoustics, sound isolation modelling, sound propagation modelling etc. It can be applied in libraries, hospitals, laboratories, lecture rooms, meditation rooms amongst many others.

III. RESEARCH OBJECTIVES

The main objective for this study was:

- a) To minimise the noise in library as much as possible.
- b) To increase the environment as more conducive for studies.
- c) To increase the efficiency of students.
- d) To eliminate the noise pollution.

IV. INSTALLATION AND TECHNIQUES

1. Microcontroller

A micro controller is an inexpensive single chip computer. Single chip computer means that the entire computer system lies within the confines of the integrated circuit chip. The micro controller on the encapsulated sliver of silicon has features similar to those of our standard personal computer. Primarily, the micro controller is capable of storing and running a program. The micro controller contains a CPU , RAM, ROM , I/O lines, serial and parallel ports, timers and sometimes other built in peripherals as A/D (analog to digital) and D/A (digital to analog) converters[6].

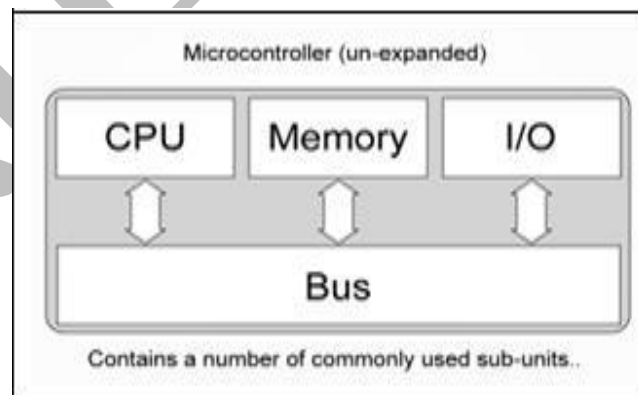

Fig - Basic Microcontroller

Most microcontrollers will also combine other devices such as;

- I. A Timer module to allow the micro controller to perform tasks for certain time periods.
- II. A serial I/O port to allow data to flow between the micro controller and other devices such as a PC or another micro controller.

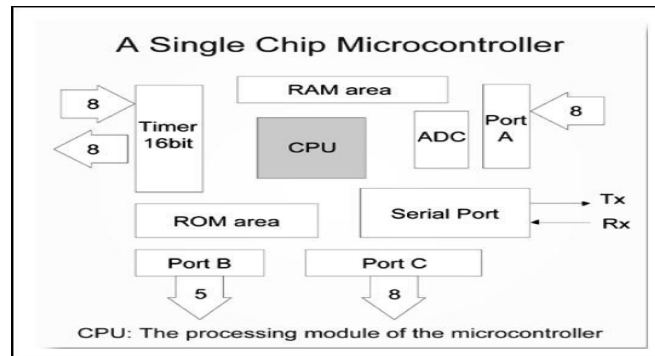

Fig - Microcontroller

The above figure illustrates a typical micro controller device and the different sub units integrated onto the micro controller.

8051 microcontroller has 128 bytes of RAM, 8K bytes of on-chip ROM, two timers, one serial port, and four ports (each 8-bits wide) all on a single chip. The 8051 is an 8-bit processor i.e. the CPU can work on only 8 bits of data at a time. The fixed amount of on-chip ROM, RAM, and number of I/O ports in microcontroller makes them ideal for many applications in which cost and space are critical [6].

Microcomputer with 8K bytes of Flash programmable and erasable read only memory (PEROM). The on-chip Flash allows the program memory to be reprogrammed in-system or by a conventional nonvolatile memory programmer. By combining a versatile 8-bit The AT89S52 is a low-power, high-performance CMOS 8-bit CPU with Flash on a monolithic chip, the Atmel AT89S52 is a powerful microcomputer, which provides a highly flexible and cost-effective solution to many embedded control applications.

Features:-

- Compatible with MCS-52™ Products
- 8K Bytes of In-System Reprogrammable Flash Memo.
- Fully Static Operation: 0 Hz to 24 MHz
- Three-level Program Memory Lock
- 128 x 8-bit Internal RAM
- 32 Programmable I/O Lines
- Two 16-bit Timer/Counters
- Six Interrupt Sources.

2. Step Down Transformer

A step down transformer is one whose secondary voltage is less than its primary voltage. It is designed to reduce the voltage from the primary winding to the secondary winding. This kind of transformer “steps down” the voltage applied to it. As a step-down unit, the transformer converts high-voltage, low-current power into low-voltage, high-current power. The larger-gauge wire used in the secondary winding is necessary due to the

increase in current. The primary winding, which doesn't have to conduct as much current, may be made of smaller-gauge wire.

Step-Down Transformer Considerations

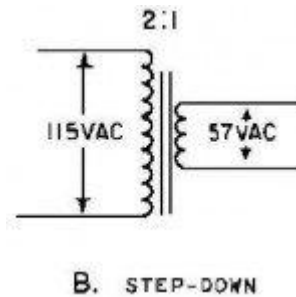

It is possible to operate either of these transformer types backwards (powering the secondary winding with an AC source and letting the primary winding power a load) to perform the opposite function: a step-up can function as a step-down and visa-versa. One convention used in the electric power industry is the use of "H" designations for the higher-voltage winding (the primary winding in a step-down unit; the secondary winding in a step-up) and "X" designations for the lower-voltage winding. One of the most important considerations to increase transformer efficiency and reduce heat is choosing the metal type of the windings. Copper windings are much more efficient than aluminium and many other winding metal choices, but it also costs more. Transformers with copper windings cost more to purchase initially, but save on electrical cost over time as the efficiency more than makes up for the initial cost.

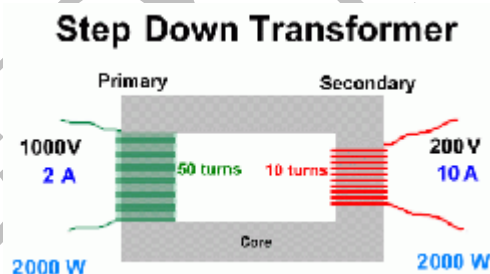

3. Capacitors:

A capacitor (originally known as a condenser) is a passive two-terminal electrical component used to store energy electrostatically in an electric field. The forms of practical capacitors vary widely, but all contain at least two electrical conductors (plates) separated by a dielectric (i.e., insulator). The conductors can be thin films of metal, aluminium foil or disks, etc. The 'nonconducting' dielectric acts to increase the capacitor's charge capacity. A dielectric can be glass, ceramic, plastic film, air, paper, mica, etc. Capacitors are widely used as parts of electrical circuits in many common electrical devices. Unlike a resistor, a capacitor does not dissipate energy. Instead, a capacitor stores energy in the form of an electrostatic field between its plates. When there is a potential difference across the conductors (e.g., when a capacitor is attached across a battery), an electric field develops across the dielectric, causing positive charge (+Q) to collect on one plate and negative charge (-Q) to collect on the other plate. If a battery has been attached to a capacitor for a sufficient amount of time, no current can flow through the capacitor. However, if an accelerating or alternating voltage is applied across the leads of the capacitor, a displacement current can flow.

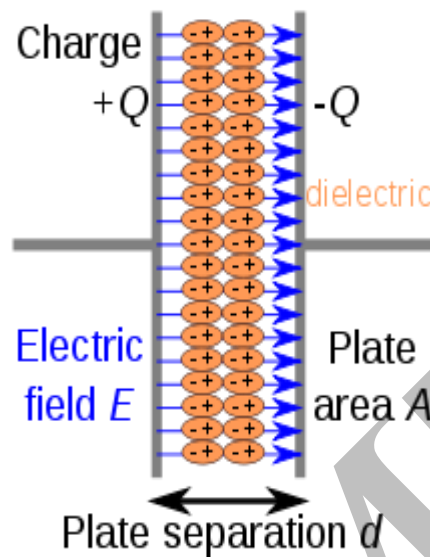
A simple demonstration of a parallel-plate capacitor**4. Diodes:-**

In electronics, a diode is a two-terminal electronic component with asymmetric conductance; it has low (ideally zero) resistance to current in one direction, and high (ideally infinite) resistance in the other. A semiconductor diode, the most common type today, is a crystalline piece of semiconductor material with a p-n junction connected to two electrical terminals. A vacuum tube diode has two electrodes, a plate (anode) and a heated cathode. Semiconductor diodes were the first semiconductor electronic devices. The discovery of crystals' rectifying abilities was made by German physicist Ferdinand Braun in 1874. The first semiconductor diodes, called cat's whisker diodes, developed around 1906, were made of mineral crystals such as galena. Today, most diodes are made of silicon, but other semiconductors such as selenium or germanium are sometimes used

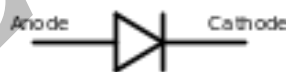
**P-N junction diode**

A p-n junction diode is made of a crystal of semiconductor. Impurities are added to it to create a region on one side that contains negative charge carriers (electrons), called n-type semiconductor, and a region on the other side that contains positive charge carriers (holes), called p-type semiconductor. When two materials i.e. n-type and p-type are attached together, a momentary flow of electrons occur from n to p side resulting in a third region where no charge carriers are present. It is called Depletion region due to the absence of charge carriers (electrons and holes in this case). The diode's terminals are attached to each of these regions. The boundary between these two regions, called a p-n junction, is where the action of the diode takes place. The crystal allows electrons to flow from the N-type side (called the cathode) to the P-type side (called the anode), but not in the opposite direction.

5. Crystal Oscillator:

A crystal oscillator is an electronic oscillator circuit that uses the mechanical resonance of a vibrating crystal of piezoelectric material to create an electrical signal with a very precise frequency. This frequency is commonly used to keep track of time (as in quartz wristwatches), to provide a stable clock signal for digital integrated circuits, and to stabilize frequencies for radio transmitters and receivers. The most common type of piezoelectric resonator used is the quartz crystal, so oscillator circuits incorporating them became known as crystal oscillators, but other piezoelectric materials including polycrystalline ceramics are used in similar circuits. Quartz crystals are manufactured for frequencies from a few tens of kilohertz to hundreds of megahertz. More than two billion crystals are manufactured annually. Most are used for consumer devices such as wristwatches, clocks, radios, computers, and cell phones. Quartz crystals are also found inside test and measurement equipment, such as counters, signal generators, and oscilloscopes

Operation

A crystal is a solid in which the constituent atoms, molecules, or ions are packed in a regularly ordered, repeating pattern extending in all three spatial dimensions.

Almost any object made of an elastic material could be used like a crystal, with appropriate transducers, since all objects have natural resonant frequencies of vibration. For example, steel is very elastic and has a high speed of sound. It was often used in mechanical filters before quartz. The resonant frequency depends on size, shape, elasticity, and the speed of sound in the material. High-frequency crystals are typically cut in the shape of a simple, rectangular plate. Low-frequency crystals, such as those used in digital watches, are typically cut in the shape of a tuning fork. For applications not needing very precise timing, a low-cost ceramic resonator is often used in place of a quartz crystal.

6. Relays:-

A relay is an **electrically operated switch**. Current flowing through the coil of the relay creates a magnetic field which attracts a lever and changes the switch contacts. The coil current can be on or off so relays have two switch positions and they are **double throw (changeover)** switches.

Relays allow one circuit to switch a second circuit which can be completely separate from the first. For example a low voltage battery circuit can use a relay to switch a 230V AC mains circuit. There is no electrical connection inside the relay between the two circuits; the link is magnetic and mechanical.

The coil of a relay passes a relatively large current, typically 30mA for a 12V relay, but it can be as much as 100mA for relays designed to operate from lower voltages. Most ICs (chips) cannot provide this current and a transistor is usually used to amplify the small IC current to the larger value required for the relay coil. The maximum output current for the popular 555 timer IC is 200mA so these devices can supply relay coils directly without amplification. ULN 2003 circuit board is used in this research project.

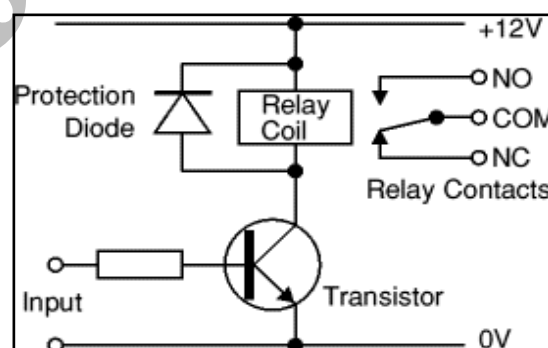

Fig. - Relay

V. BLOCK DIAGRAM

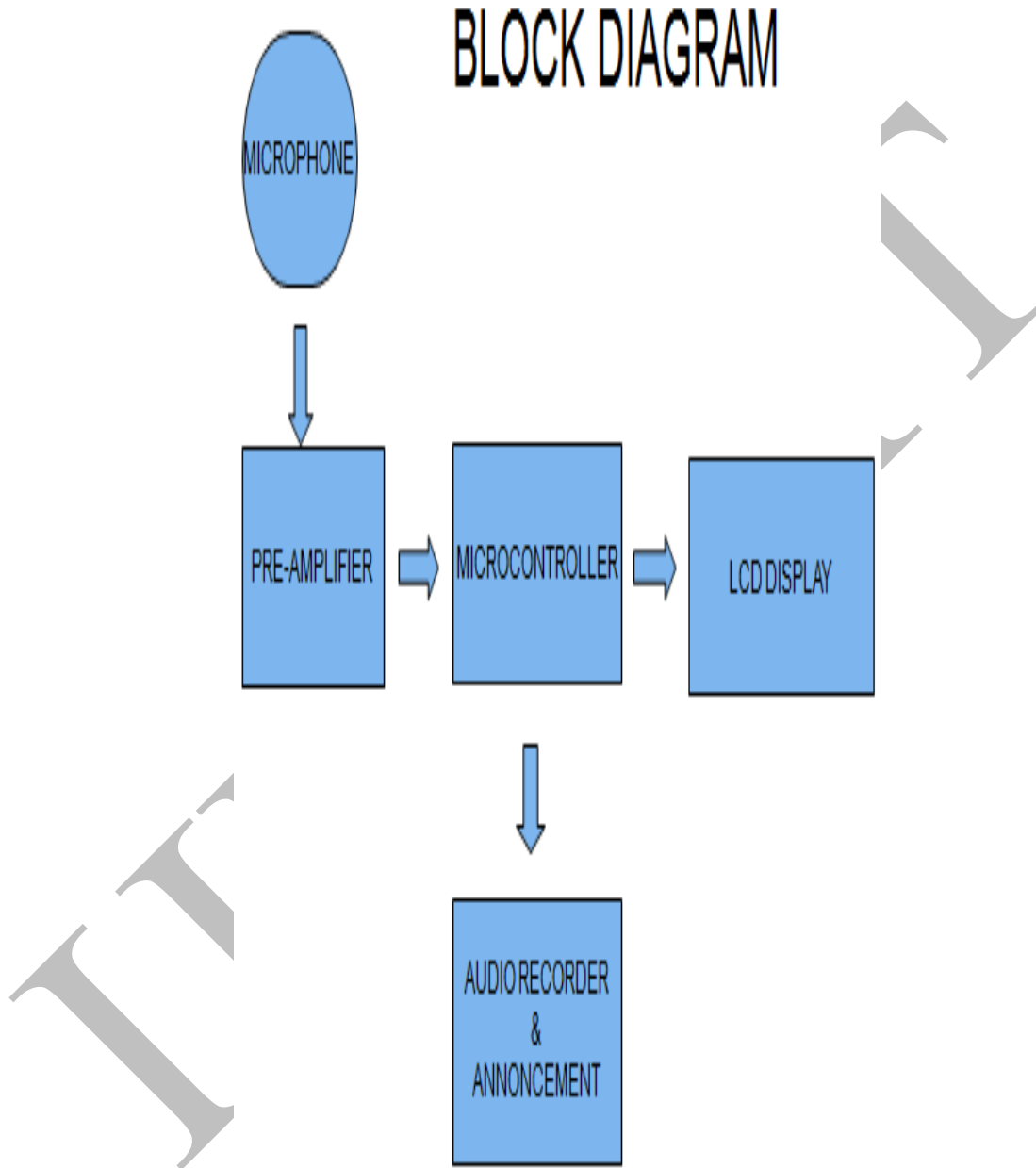
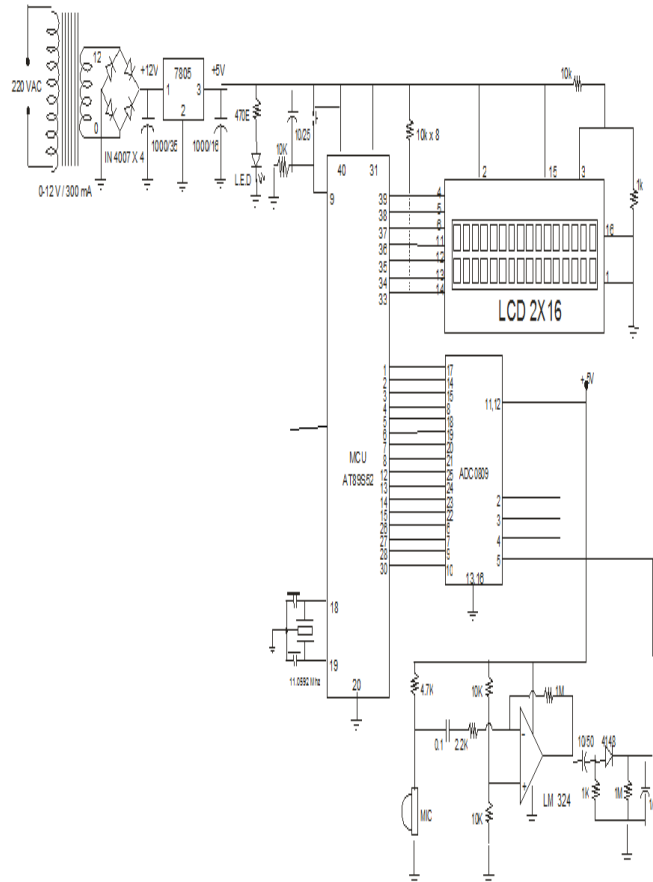

Fig - Block Diagram

VI. CIRCUIT DIAGRAM



VII. CONCLUSION

The sound level will be controlled efficiently because of the audio announcement which sends a pre recorded message instructing the students to lower their voice. Thus it provides a conducive environment for studying. A sound level meter is simply a device with audio-frequency sensing capabilities that is controlled essentially by a microcontroller in turn measuring, comparing and regulating audio signals all in a bid to reduce noise level in a library as well as maintain a stable audio frequency throughout the library environment. This project focuses on measuring the various sound levels present in a library all in a bid to limit unnecessary noise in the library through audio announcement once the critical sound level has been exceeded.

VIII. APPLICATIONS

- 1. Used in libraries.
- 2. For handling of environmental studies.
- 3. At Airports and metro stations.

IX. FUTURE IMPLEMENTATIONS

The future prospects could be acoustical or environmental studies and decreasing noise pollution as much as possible. There will not be any need of man monitoring in library if centralised system could reduce the noise level in the libraries.

XI. REFERENCES

1. U. O. Georgia and K. I. N. Nwalo, "Perception by Undergraduate Students of the Environmental Conditions and Resources Availability in Selected University Libraries in Nigeria," African Journal of Library and Information Science, vol. 21, no. 1, pp. 73-78, 2011.
2. K. I. N. Nwalo, "Measure of Library Effectiveness in Nigerian Polytechnic Libraries with Emphasis on User Satisfaction," Journal of Librarianship information science in Africa, vol. 1, no. 1, pp. 41-50, 2001.
3. A. N. G. Alutu and C. N. Ojogwu, "Study behavior techniques and learning environment of undergraduates in the university: A case study of University of Benin," Emotan Journal of fine and Applied Arts, University of Benin, vol. 1, no. 1, pp. 41-50, 2002.
4. Nathan David, Anyika Chidinma Venetia Nina, Journal of Electronics and Communication Engineering Research
5. Johns Hopkins, International Journal of Environmental Health
6. M. Nwadiani, "Educational management for sub-Sahara Africa," Dimensions of Education series. Nigeria Society for Educational Planning (NSEP), Nigeria, no. 2.